

MUMMY QUILT

Riley Blake
DESIGNS®



55 1/2" x 64 1/2"

 **FRANK**★
and friends

 = Intermediate

My Mind's Eye
PAPER GOODS

04/01/2026

MUMMY QUILT

FINISHED QUILT SIZE 55 ½" × 64 ½"

Please read all instructions before beginning this project.
Yardage calculated using a 42" usable width of fabric.

Pattern designed by The RBD Designers.

GENERAL INSTRUCTIONS

Please check www.rileyblakedesigns.com/pattern-updates or scan the QR Code for any updates before starting this project.

This pattern requires a basic knowledge of quilting and foundation paper piecing techniques and terminology. The quilt and block diagrams portrayed are virtual images. The layout and look of your project may differ when using actual fabric. It is not recommended to prewash fabric before cutting and assembling.



WOF = Width of Fabric
RST = Right Sides Together

FABRIC REQUIREMENTS

Fabric is from the Frank and Friends collection unless stated otherwise.

(1) 10-17470-42 10" Stacker

⅞ Yard of Each:

C17474-CLOUD Webs

C705-HALLOWEEN Pin Dot

Additional Fabrics:

10" square C120-BRIGHTWHITE Confetti Cotton™ Solid

⅓ yard C120-RILEYBLACK Confetti Cotton™ Solid

1 ⅓ yards GC17474-BLACK Web

⅝ yard C17473-BLACK Diamonds (binding)



OTHER SUPPLIES

Basic Sewing Supplies

1 ⅞ yards WB640-RILEYGRAY Dapple Dot (wide back backing)

Batting

Foundation paper

Fusible web

CUTTING INSTRUCTIONS

When cutting fabrics, use a straight edge ruler and rotary cutter. Measurements include ¼" seam allowance. Label, allocate, and organize all cuts as noted.



10" Stacker

From each of (15) 10" × 10" squares, cut:

(1) 9 ½" × 9 ½" square. Label as A.

From each of (15) 10" × 10" squares and referring to the Cutting Diagram below, cut:

(2) 2 ¼" × 4 ¼" rectangles for Foundation A10–A11.

(2) 2 ¼" × 3 ½" rectangles for Foundation B3–B4.

(2) 2" × 9 ½" rectangles. Label as B.

(2) 2" × 3 ¾" rectangles for Foundation A8–A9.

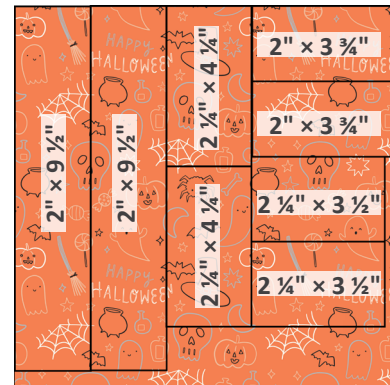

Bright White Confetti Cotton™ Solid

Cut (30) Inner Eye Templates.



Riley Blake Confetti Cotton™ Solid

Cut (30) Outer Eye Templates.

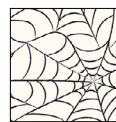

Cloud Webs

Cut (8) 2 ¾" × WOF strips. Subcut:

(15) 2 ¾" × 7 ¼" rectangles for Foundation A6.

(30) 2 ¾" × 7" rectangles for Foundation A1 and A3.

Cut (2) 2" × WOF strips. Subcut:

(15) 2" × 4 ¾" rectangles for Foundation B2.

MUMMY QUILT

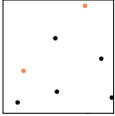

Halloween Pin Dot

- Cut (3) 2 ¾" × WOF strips. Subcut:
(15) 2 ¾" × 7 ½" rectangles for Foundation A2.
- Cut (3) 2" × WOF strips. Subcut:
(15) 2" × 5 ½" rectangles for Foundation B1.
(5) 1 ¾" × 7 ¼" rectangles for Foundation A5.
- Cut (4) 1 ¾" × WOF strips. Subcut:
(10) 1 ¾" × 7 ¼" rectangles for Foundation A5.
(15) 1 ¾" × 5 ¼" rectangles for Foundation A7.
- Cut (3) 1 ½" × WOF strips. Subcut:
(15) 1 ½" × 5 ½" rectangles for Foundation A4.



Black Web

- Cut (6) 5 ½" × WOF strips. Piece together end-to-end; subcut:
(2) 5 ½" × 55 ½" strips. Label as C.
(2) 5 ½" × 54 ½" strips. Label as D.



Black Diamonds

- Cut (7) 2 ½" × WOF strips. Set aside for binding.

SEWING TECHNIQUES

Sew all seams RST and with a ¼" seam allowance unless stated otherwise. Refer to the Quilt Layout Diagram for placement of the fabrics. Press seams as desired unless stated otherwise. Dimensions listed in steps are unfinished sizes.

APPLIQUÉ PREPARATION

Instructions are provided for raw edge fusible appliqué. Seam allowances are not included on the Templates; add them if using another appliqué technique.

To prepare and cut the appliqué pieces:

- Place the Templates right side up on a light table or window.
Note: The Templates are already reversed for ease of use.
- Trace the individual labeled shapes onto the paper side of the fusible web, leaving at least ¼" of space around each traced shape. Transfer the Template names to the fusible paper as well.
- Roughly cut outside the drawn line of each shape, leaving at least ¼" of fusible web.

Note: For softer finished appliqué, also remove the interior of the drawn shape, leaving at least ½" of fusible web inside of the drawn line. Discard or reuse any excess for any smaller shapes.

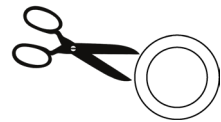
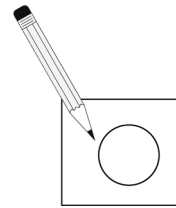

- Fuse the traced shapes to the WRONG side of the specified fabric following the manufacturer's instructions. Once cool, cut out each shape exactly on the drawn lines. Do NOT remove the paper backing until ready to fuse in place.

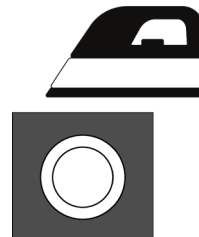

MUMMY QUILT

BLOCK ASSEMBLY

1. Print (15) each of the Foundation Templates A and B from pages 7-8 onto foundation paper. Ensure the 1" square is accurate for sizing. Cut out foundation patterns roughly $\frac{1}{4}$ " outside dashed lines. Note: Page 8 features (3) of Foundation Template B, so you only need to print that page (5) times for (15) of that template.
2. Gather (1) each of pieces for Foundation A1-A7 and B1-B2. From one print, gather (2) B-rectangles and pieces for Foundation A8-A11 and B3-B4.
3. Place a foundation paper printed side down. Place the required position 1 fabric right side up over foundation paper position 1. Pin in place. Hold paper up to light to check that fabric piece completely covers position 1, with at least $\frac{1}{4}$ " outside the solid lines, and any seam allowances along the outside edge.

Unmarked Side of Paper

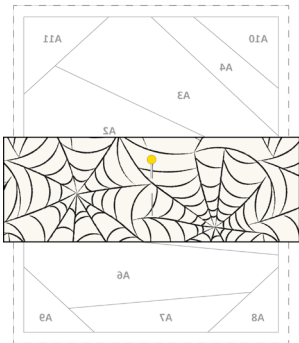

Marked Side of Paper

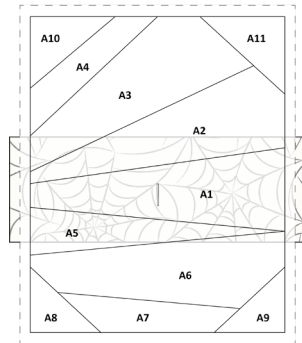

4. Turn the foundation paper marked side up. Referring to the diagram, fold the foundation paper back on the marked stitching line between positions 1 and 2. Measure $\frac{1}{4}$ " from the folded edge of the foundation paper and trim using a rotary cutter and ruler to make a $\frac{1}{4}$ " seam allowance.

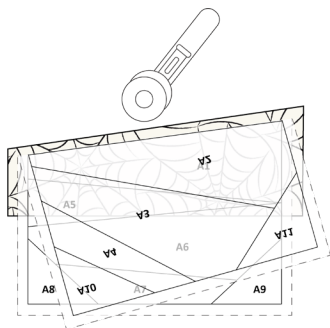

5. On the unmarked side of the foundation paper, align the edge of the position 2 fabric with the trimmed edge of the position 1 fabric RST. Check the placement of the position 2 rectangle. Next, on the marked side of the foundation paper and with a shortened stitch length, sew on the stitching line between positions 1 and 2 through all layers, extending stitching past beginning and end of the line by a few stitches. Turn the paper over and press the position 2 fabric open (the fabric should completely cover position 2 and any seam allowances along the outside edge).

Marked Side of Paper

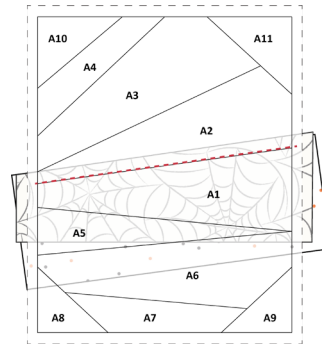

Unmarked Side of Paper

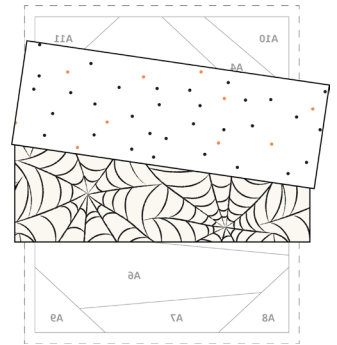

6. Repeat the trimming and sewing process from steps 4-5 to add fabric pieces in numerical order until all pieces have been sewn to the foundation paper.
7. Using a rotary cutter and a ruler, trim along the dashed outer lines to make a foundation-pieced unit.

Marked Side of Paper

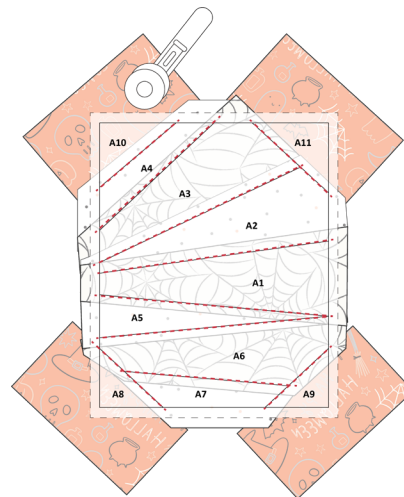

Trimmed Unit



MUMMY QUILT

8. Repeat steps 3-7 using (1) Foundation Template B to make the unit shown below.

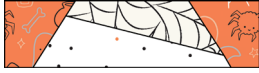

9. Sew (1) trimmed foundation-pieced A unit and (1) trimmed foundation-pieced B unit together as shown below. Remove the foundation paper carefully to avoid pulling the seams or distorting the fabric. Next, sew (1) B-rectangle to each side to make (1) Mummy Block.

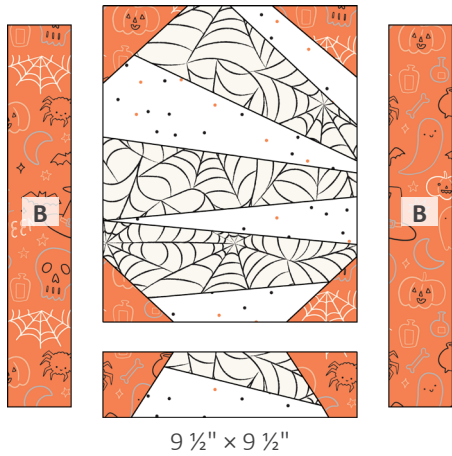

10. Arrange (2) Outer Eye and (2) Inner Eye shapes along the A1 piece as shown below. Note: The Inner Eyes can rotate placement, so refer to the cover image for inspiration. Fuse the shapes in place following the manufacturer's instructions. Once cool, stitch around the edge of each shape using a straight or small zigzag stitch in your choice of matching, contrasting, or invisible thread.

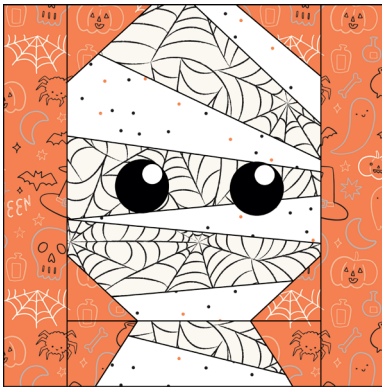

11. Repeat steps 2-10 to make (15) total Mummy Blocks.

QUILT ASSEMBLY

12. Arrange (15) A-squares and (15) Mummy Blocks, alternating squares and blocks as shown below. Sew the squares and blocks together into rows. Next, sew the rows together to make the quilt center.



13. Sew (1) D-strip to each side of the quilt center as shown in the Quilt Layout Diagram on page 6. Next, sew (1) C-strip to the top and bottom to complete the quilt top.

MUMMY QUILT

QUILT LAYOUT DIAGRAM



55 1/2" x 64 1/2"

FINISHING INSTRUCTIONS

14. Layer the quilt top, batting, and backing. Baste the quilt layers together and quilt as desired. Sew the Black Diamonds binding strips together end-to-end. Then bind the trimmed, finished quilt using your favorite binding method.

Enjoy and share your quilt using the hashtags: [#frankandfriendsfabric](#), [#mummyquilt](#), [#rileyblakedesigns](#), and [#iloverileyblake](#).

MUMMY QUILT

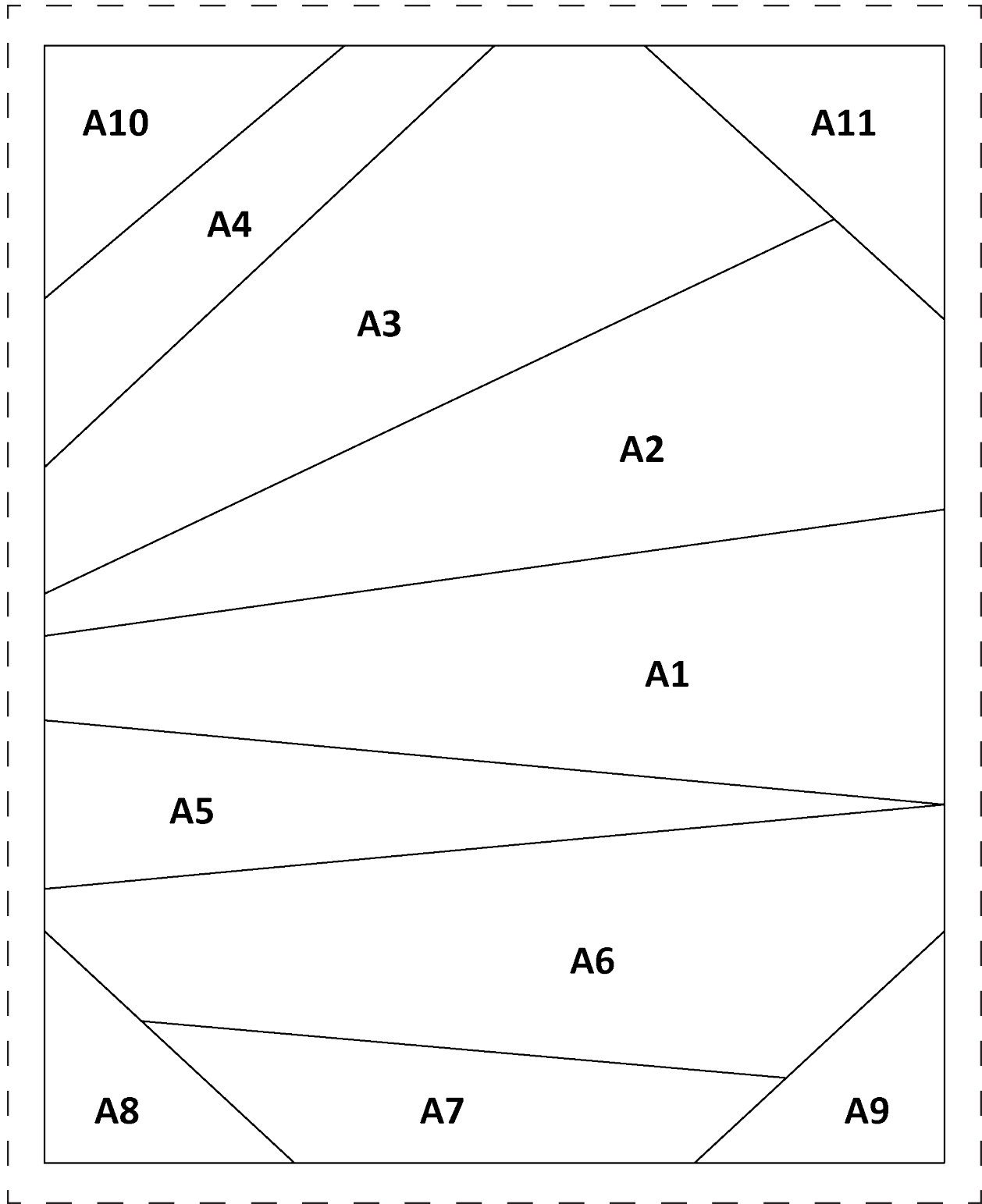

1" TEST
SQUARE

MUMMY QUILT

